

C2102S-100



- ▶ USDA and 3-A accepted conveyors that meet the stringent sanitary requirements of the food, dairy and pharmaceutical industries.
- ▶ Solution that contributes to dust-free conveying.
- ▶ Turnkey conveyor that is easy to install and start up.
- ▶ Manual dismounting and cleaning.
- ▶ Low sound level.
- ▶ Fully pneumatic.
- ▶ External filter shock assembly.
- ▶ Gore Sinbran filters with PTFE membrane.

TECHNICAL DATA

Description	Unit	Value
Feed pressure range	MPa	0.4–0.6
Air consumption range	NI/s	5–7
Vacuum range	-kPa	61–75
Noise level range	dBA	72–76
Material		ASTM 316L, Q
Temperature range	°C	0–60
Weight	kg	29.0
Safety classification		IP54
Filter area	m ²	0.11
Material batch volume	l	3.8
Min particle size	µm	0.5

CAPACITY

Capacity ton/h at different conveying distances			
5 m	10 m	20 m	30 m
0.90	0.45	0.20	–

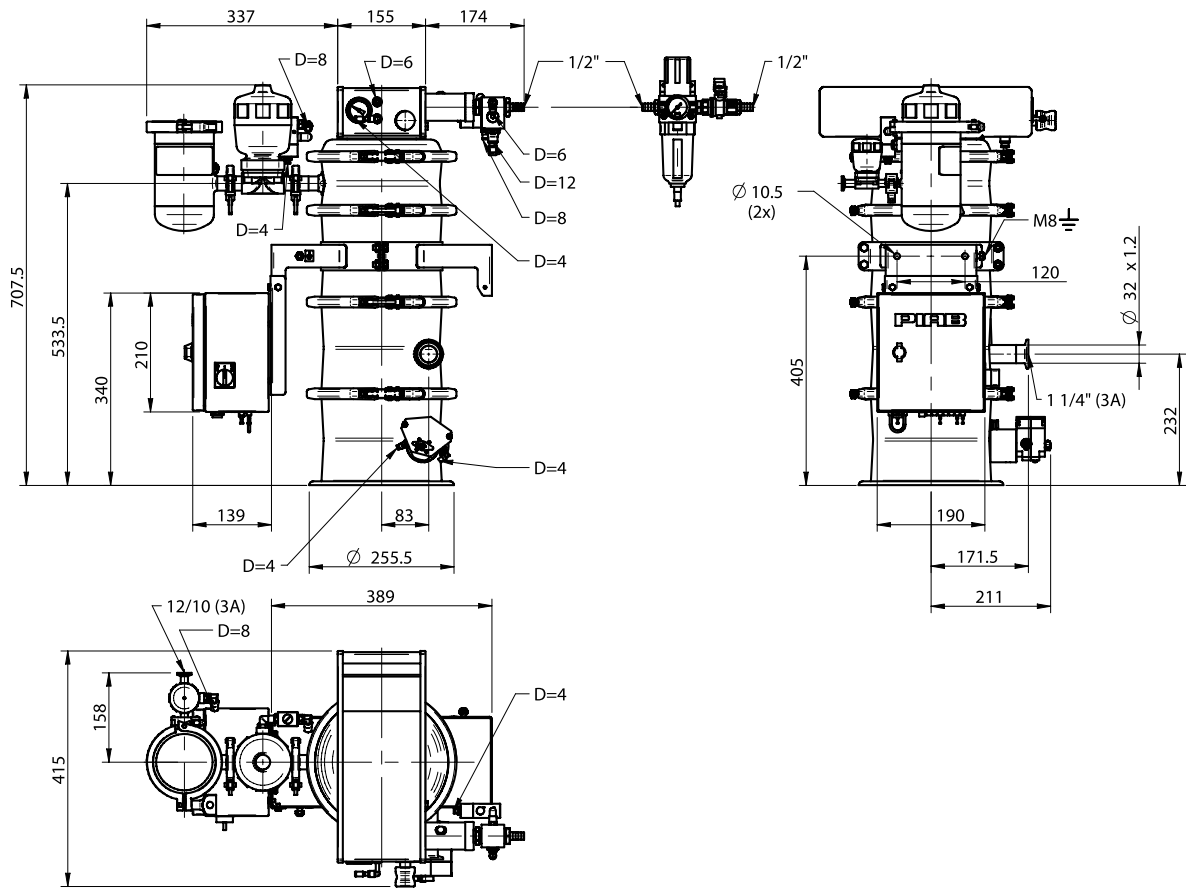

Conveyors C
COMPLETE