

Movotrak T90 and T130

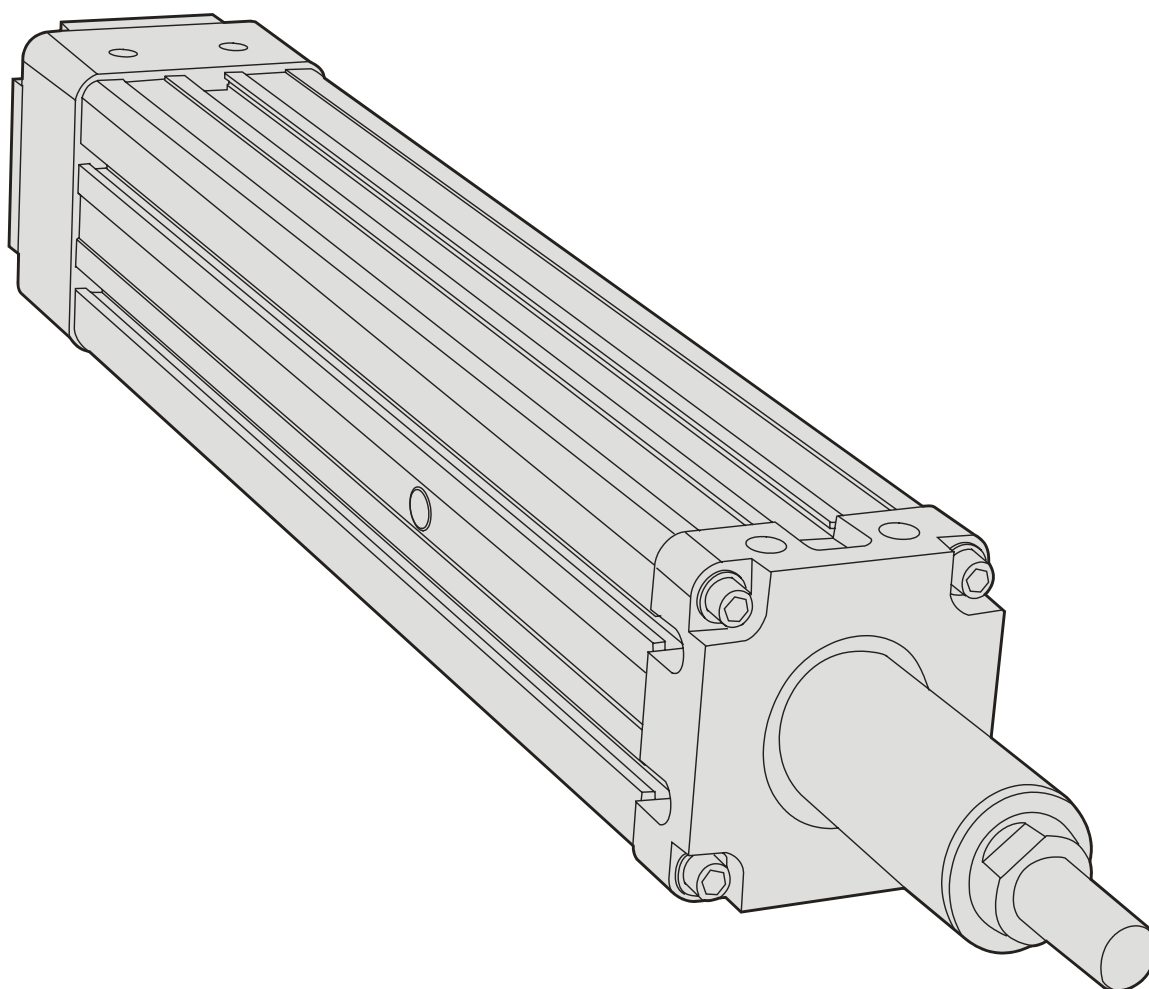

Installation and Service Manual
Edition: 2
DW110352gb-0506

Version History

Edition Number	Edition Date	Reason for Revision
1	2004	Manual created
2	2005-02-10	Updated with new T90 versions

DANAHER MOTION is a registered trademark of Danaher Corporation. Danaher Motion makes every attempt to ensure accuracy and reliability of the specifications in this publication. Specifications are subject to change without notice. Danaher Motion provides this information "AS IS" and disclaims all warranties, express or implied, including, but not limited to, implied warranties of merchantability and fitness for a particular purpose. It is the responsibility of the product user to determine the suitability of this product for a specific application.

©2004 Danaher - Printed in Sweden. All rights reserved.

Table of Contents

1. Type designation system.....	4
2. Mounting instructions.....	5
2.1 Installation.....	5
2.2 Connection of load.....	6
2.3 Motor flange.....	6
2.4 Feet mounting kit.....	7
2.5 Trunnion mounting kit.....	7
2.6 Mounting of worm gear type BS40 / BS50.....	8
2.7 Installation of magnetic sensors.....	8
3. Service and maintenance	9
3.1 General maintenance instructions.....	9
3.2 Lubrication	9
4. Technical data	10
4.1 Technical data	10

1. Type designation system

Designation example:	T	09	-	B	4010	M	S	052
Unit type Movotrak precision actuator	T							
Size 90 130		09 13						
Hyphen			-					
Drive type Ball screw and ball nut				B				
Screw diameter / lead / tolerance 25 mm / 05 mm / T7 25 mm / 10 mm / T7 25 mm / 25 mm / T7 32 mm / 20 mm / T7 32 mm / 32 mm / T7 40 mm / 10 mm / T7 40 mm / 20 mm / T7 40 mm / 40 mm / T7					2505 2510 2525 3230 3232 4010 4020 4040			
Engineering unit Metric						M		
Adapter type M16 × 1,5 outside thread M16 × 2 inside thread M20 × 1,5 outside thread M20 × 1,5 inside thread M27 × 2 outside thread M27 × 2 inside thread M33 × 2 outside thread M33 × 2 inside thread M30 × 2 inside thread							N P Q R S T U V X	
Ordering length L [cm]								...

Table 1: Type designation system for Movotrak

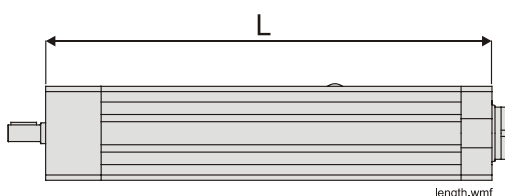

Figure 1: definition of ordering length L

2. Installation

2.1 Mounting instructions

1

T90

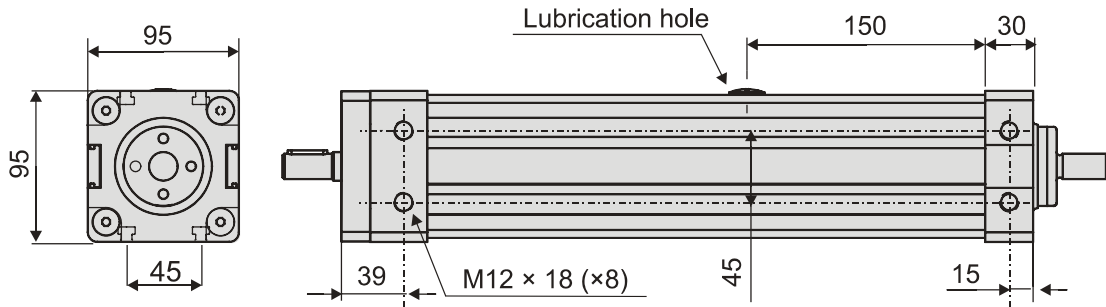

T130

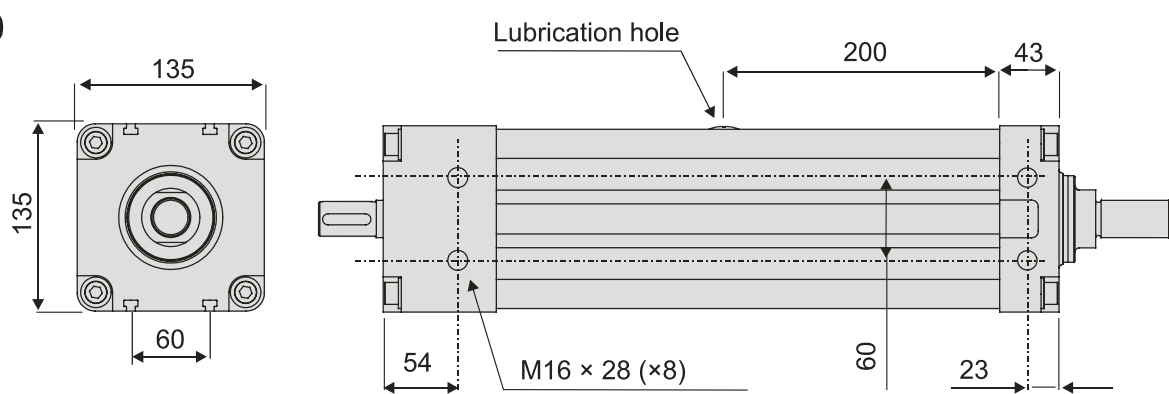

mounting.wmf

2

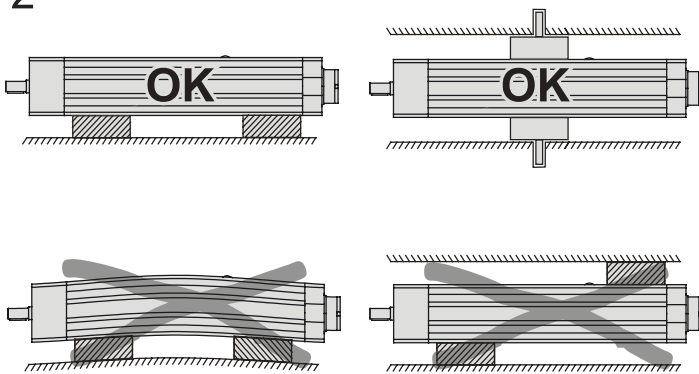

3

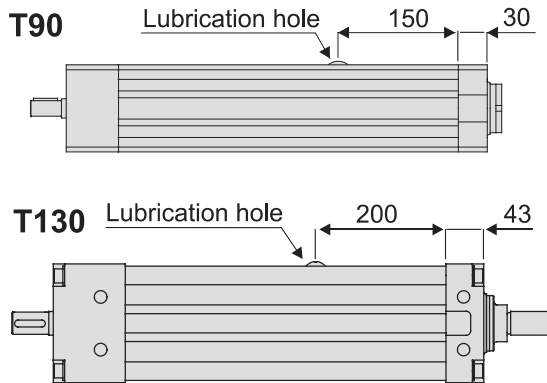
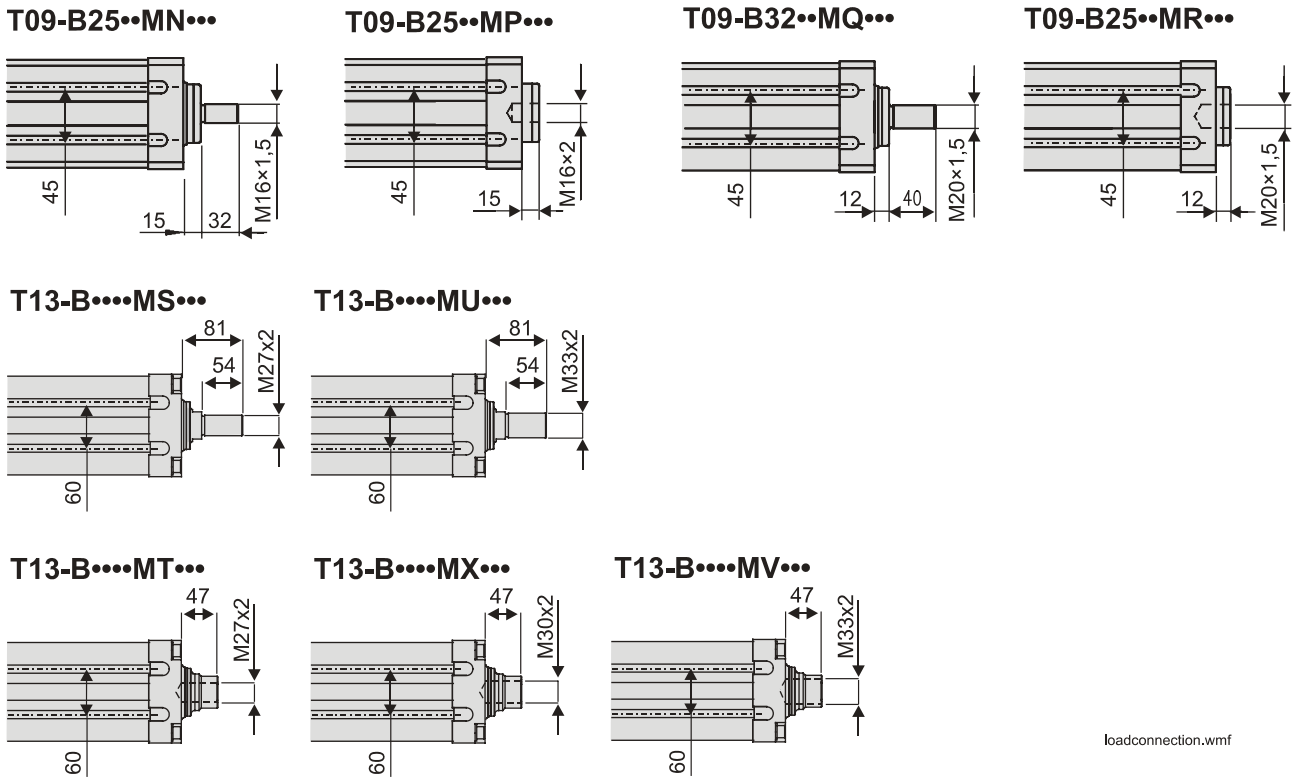

Figure 2: mounting instructions

1. The actuators are equipped with T-slots along the profile and threaded side holes in the front and rear housings, which can be used for mounting.
2. Only mount the actuator to one side if not trunnion mounting is used. Do not mount the actuator so that the profile is deformed.
3. Mount the actuator so that the lubrication hole is accessible.

2.2 Connection of load



loadconnection.wmf

Figure 3: connection of load

2.3 Motor flange

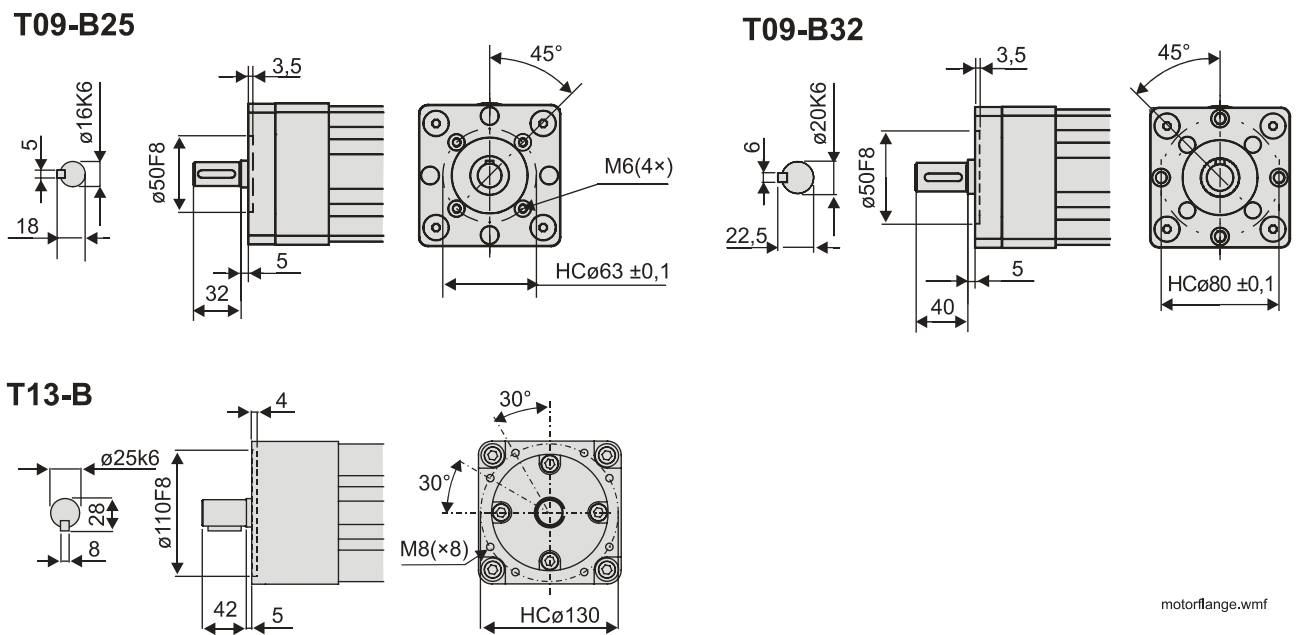

motorflange.wmf

Figure 4: motor flanges

2.4 Feet mounting kit

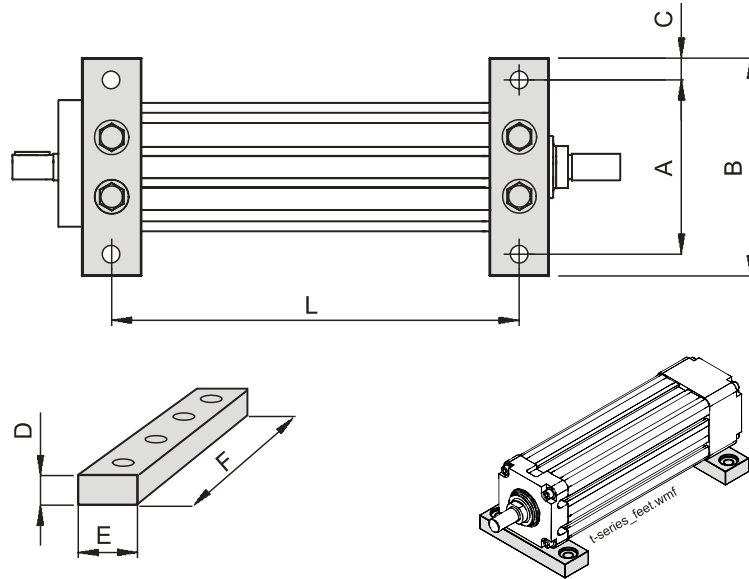

Figure 5: mounting feet

	A	B	C	D	E	F	L	Tightening torque [Nm]
T09-B25	125	155	15	20	40	155	Smax + 141	78
T09-B32	125	155	15	20	40	155	Smax + 162	78
T13-B40	176	220	22	30	60	220	Smax + 216	220

Table 2: mounting feet dimensions

2.5 Trunnion mounting kit

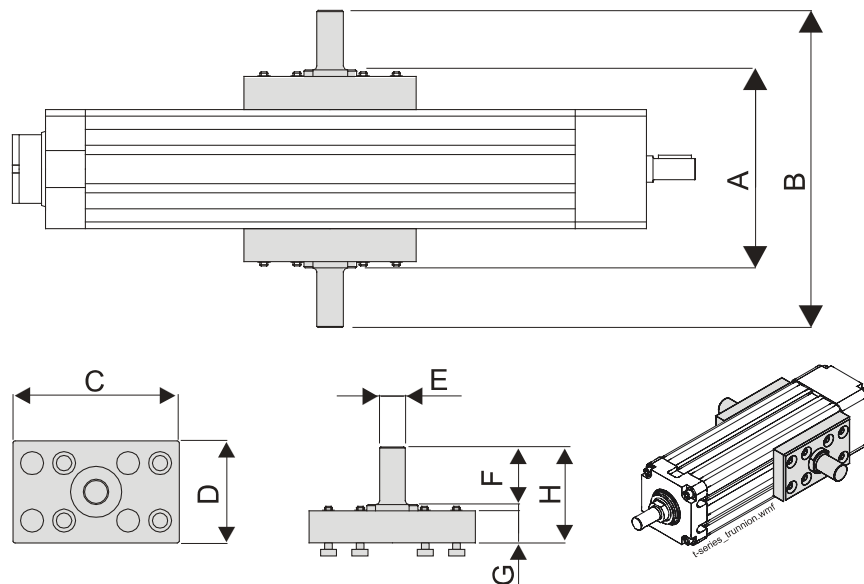

Figure 6: trunnion

	A	B	C	D	E	F	G	H	Tightening torque [Nm]
T09-B	150	240	130	80	∅20 f8	45	25	75	11
T13-B	316	210	180	110	∅35 f8	63	30	93	45

Table 3: trunnion dimensions

Make sure to mount the bearings on the trunnion shafts as close to the unit as possible.

2.6 Mounting of worm gear type BS40 / BS50

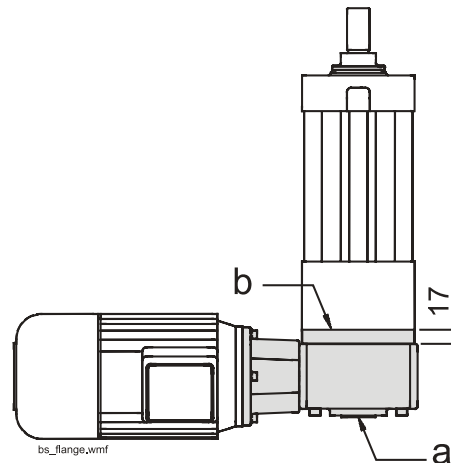

Figure 5: flange for worm gear type BS40 / BS50

To be able to mount a worm gear (a) of type BS40 (for T90 only) or BS50 (for T130 only) an intermediate flange (b) must be used.

2.7 Installation of magnetic sensors

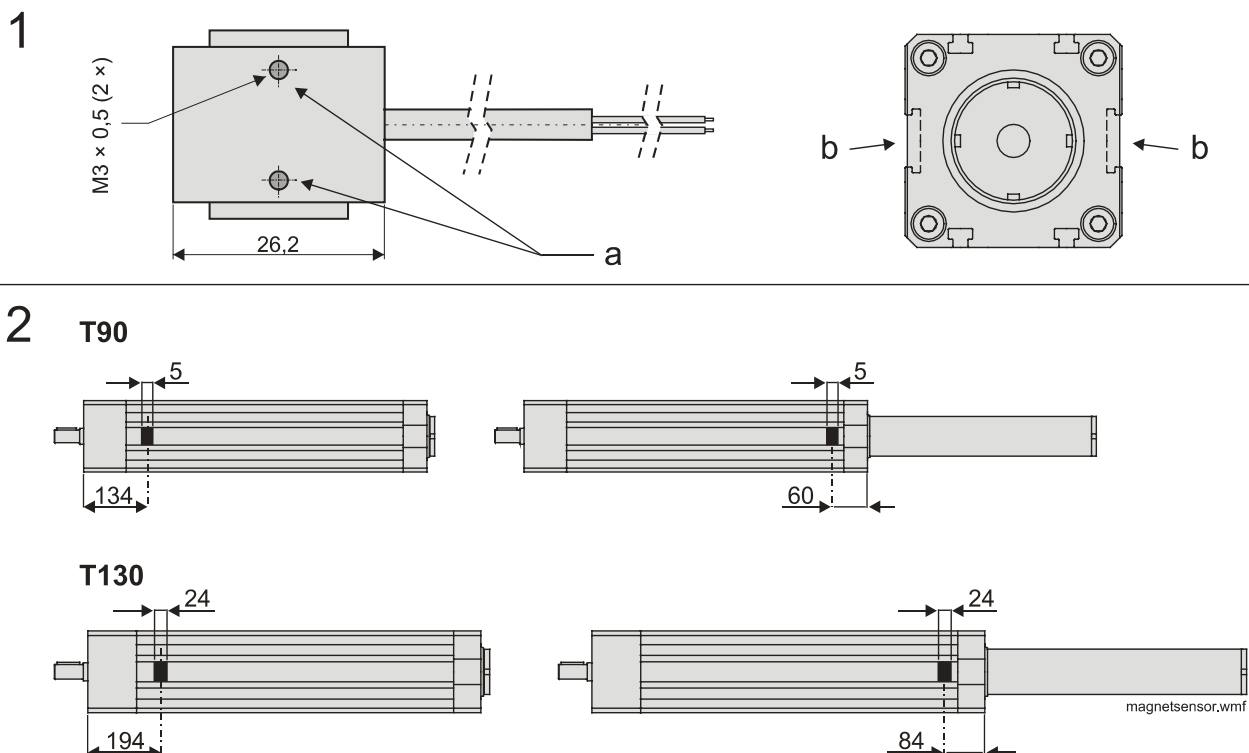

Figure 5: magnetic sensor

1. The sensors are locked in the desired position with the aid of the lock screws (a) in the T-slots (b).
2. Magnet positions at fully retracted and fully extended rod. Keep in mind that the duration of the sensor signal is dependent upon the speed and the width of the magnet (the signal is somewhat longer than the magnet due to the spread of the magnetic field). This means that the relay or input device, which shall detect the signal, must be capable of detecting the duration of the signal in question.
3. Strong magnets are used of safety reasons. This will create a long signal but can give the effect that the signal is split in two with an interrupt in the middle.

3. Service and maintenance

3.1 General maintenance instructions

- The customer can perform the service and maintenance described in this manual. Other service ought to be performed by authorised personnel / service workshop.
- Follow the recommended service intervals. Replace defective parts immediately. Only use parts of the same make and type as original. Ordering data can be found in the spare part lists supplied with the unit. Also state the manufacturing number of the unit (embossed in the drive end).
- T90 anS T130 is not self-braking. This means that the load and the extension tube can move if the driving force is disconnected, or if the motor, gears or brakes are detached during service. This is even more important for vertical applications. Ensure therefore that the load is secured before service is begun.
- Check the unit in connection to lubrication. Be attentive towards the wear and function of the rod seal, the magnetic sensors, limit switches and the mounting of them. Check all connections to the support and the rod. Also be attentive towards a changed level of noise. Replace, repair or adjust.
- Keep the actuator clean. Wipe it off as required, particularly the rod. If cleaning fluid is required, use small amounts and see to it that none gets into the actuator. Do not use strong cleaning agents. Dry it fully.
- **Never** mix different types of oils / lubricants!

3.2 Lubrication of the ball screw

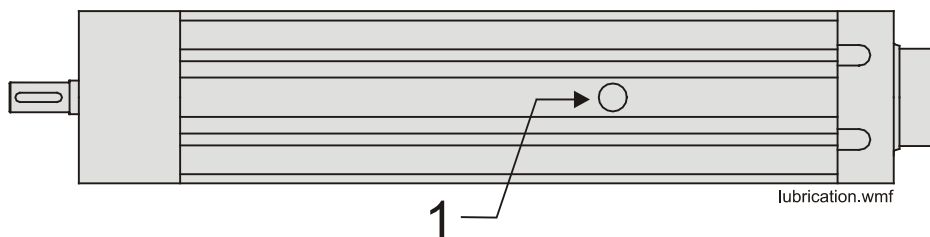

Figure 6: lubrication of the ball screw

1. The ball screw is lubricated every 600 hours of operation or every 6:th month depending on whichever comes first.
2. Recommended lubricant is Klüber Staburags NBU 30.
3. Remove the plastic plug covering the lubrication hole (1) and run the actuator to a position where the ball screw becomes visible.
4. Apply a little lubricant to the screw and run the actuator back and forth so that the lubricant is distributed.
5. Repeat point 4 a couple of times. Put back the plastic plug.

4. Technical data

4.1 Technical data

T90

		T09-B2505M	T09-B2510M	T09-B2525M
Max. speed	[m/s]	0,3	0,8	1,5
Max. radial load	Fr [N]	300	300	300
Max. axial load	Fx [N]			
static		15 000	15 000	15 000
dynamic		10 000	10 000	10 000
Repeatability	[mm]	± 0,05	± 0,05	± 0,05
Max. input speed	[rpm]	4000	4800	4800
Weight	[kg]	5 + (L ^A × 16,2)	5 + (L ^A × 16,2)	5 + (L ^A × 16,2)
Ambient temperature	[°C]	-20 – +70	-20 – +70	-20 – +70
Linear move / shaft turn	[mm]	5	10	25

		T09-B3220M	T09-B3232M
Max. speed	[m/s]	1,25	2
Max. radial load	Fr [N]	500	500
Max. axial load	Fx [N]		
static		25 000	25 000
dynamic		20 000	20 000
Repeatability	[mm]	± 0,05	± 0,05
Max. input speed	[rpm]	3750	3750
Weight	[kg]	6,5 + (L ^A × 18)	6,5 + (L ^A × 18)
Ambient temperature	[°C]	-20 – +70	-20 – +70
Linear move / shaft turn	[mm]	20	32

^A L in metres, see figure 1 for definition of L

Table 2: technical data for T90

T130

		T13-B4010M	T13-B4020M	T13-B4040M
Max. speed	[m/s]	0,4	1	2
Max. radial load	Fr [N]	800	800	800
Max. axial load	Fx [N]			
static		45 000	45 000	45 000
dynamic		40 000	35 000	15 000
Repeatability	[mm]	± 0,05	± 0,05	± 0,05
Max. input speed	[rpm]	2500	3000	3000
Weight	[kg]	18,5 + (30 × (L ^A – 0,239))	18,5 + (30 × (L ^A – 0,239))	18,5 + (30 × (L ^A – 0,239))
Ambient temperature	[°C]	-20 – +70	-20 – +70	-20 – +70
Linear move / shaft turn	[mm]	10	20	40

^A L in metres, see figure 1 for definition of L

Table 3: technical data for T130

- Page intentionally left blank -

Sales and Service

Danaher Motion products are available world wide through an extensive authorised Distributor network. These distributors offer literature, technical assistance and a wide range of models off the shelf for fastest possible delivery.

Danaher Motion sales engineers are conveniently located to provide prompt attention to customers' needs. Call the nearest office listed for ordering.

France

Danaher Motion
C.P. 80018
12, Rue Antoine Becquerel - Z.I. Sud
Bâtiment Paul Tiger 2
F-72026 Le Mans Cedex 2, France
Tel. +33 (02) 43 50 03 30
Fax. +33 (02) 43 50 03 39
E-mail: sales.france@danahermotion.com

Germany

Danaher Linear GMBH
Postfach 2008
D-72610 Nürtingen, Germany
Tel. 0180 5 24 67 90
Fax. 0180 5 24 40 85
E-mail: info@danahermotion.net

Italy

Danaher Motion srl
Via Brughetti
200 30 Bovisio Masciago, Italy
Tel. +39 (0) 362 594 260
Fax. +39 (0) 362 594 263
E-mail: info@danahermotion.it

Spain

Danaher Motion
Tollo Linear
Badal, 29–31 7th, 1st
08014 Barcelona, Spain
Tel./Fax. +34 (0) 9329 80278
E-mail: helpdesk@tollo.com

Scandinavia

Danaher Motion
Tollo Linear AB
Box 9053
SE-291 09 Kristianstad, Sweden
Tel. +46 (0)44 24 67 00
Fax. +46 (0)44 24 40 85
E-mail: helpdesk@tollo.com

United Kingdom

Danaher Motion
Fishleigh Road
Roundswell Business Park
Barnstaple, Devon
EX31 3UD, UK
Tel. +44 (0) 1271 334500
Fax +44 (0) 1271 334502
E-mail: LMSEurope@danahermotion.com